

PERFORMANCE

Model	Maximum flow rate			Maximum head	
	l/min	cu.m/hr	gall/min	metres	feet
AM50	800	48	176	38	125

Maximum power absorbed 5.5kW at 3000rpm

DIMENSIONS IN MM (APPROX.)

WEIGHT: 32.2kg

AM50

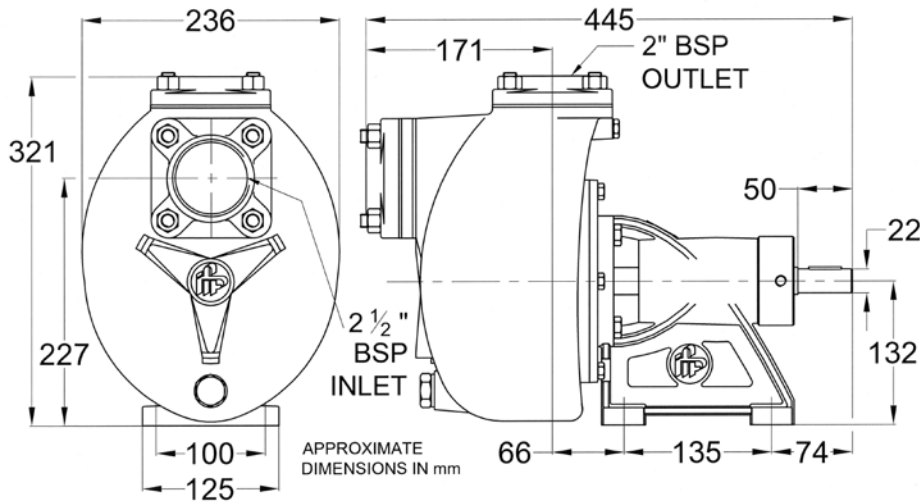

MATERIALS OF CONSTRUCTION

Pump casing	bronze
Impeller	bronze
Port counterflanges	Bronze
Shaft	stainless steel AISI316
Bearing housing	cast iron
Pump head bolts	stainless steel
O-ring static seal	nitrile rubber

Pump performance and specification are subject to alteration without notice

AVAILABLE 'A' series CLUTCHES (ask for a data sheet)

Clutch Type	Pulley Pitch Dia	Pulley Belt Section	No of Belts	FP Code
MANUAL	117mm	B	2	FP-94-8030611
MANUAL	140mm	B	2	FP-94-8050611
24v dc	152mm	SPB	1	FP-94-8110427
24v dc	145mm	A	2	FP-94-8130427

FP PUMPS

AM50

2" BRONZE SELF-PRIMING CENTRIFUGAL PUMP

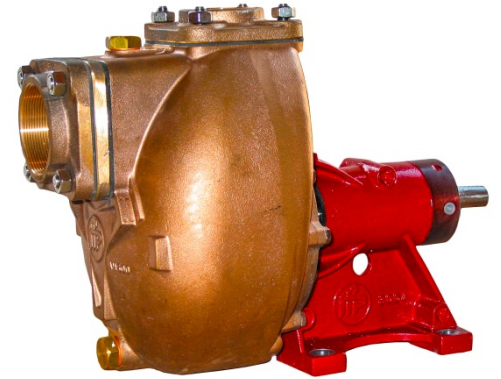

- * corrosion-resistant bronze body & impeller, with stainless steel shaft
- * self-priming up to 5m
- * available with clockwise or anti-clockwise rotation – please specify
- * carbon-ceramic mechanical shaft seal

BRONZE PUMPS

for

SEAWATER

Xylem Water Solutions UK Ltd
Bingley Road
Hoddesdon
Hertfordshire • EN11 0BU • UK

Tel: +44 (0)1462 480380
Fax: +44 (0)1462 482422
mail@cleghorn.co.uk
www.jabscoshop.com

